

HRHD410

4-channel Digital Video Recorder



Honeywell's new HRHD410 is a high-performing digital recording solution that delivers the advanced processing of a multiplexer at an affordable price. The HRHD410 features XtraStor, our advanced proprietary compression algorithm, that provides more storage on smaller media, without compromising image quality – resulting in days, weeks and even months of high-resolution video storage.

With its versatile processing capabilities, the HRHD410 can capture video at up to 120 images per second in simplex mode and up to 60 images per second in duplex mode, while allowing selection of the recording speed and picture quality for each of the camera inputs. Additional recording features include alarm and motion detection, user-defined recording schedules, and multiple-recording modes.

The HRHD410 generates compact encrypted archive video clips as self-executable files. Honeywell's minibank format produces an executable (.exe) file containing both the video clip and reader, allowing you to simply run the clip in its original, unalterable format on any PC, without the need for reader software.

HRHD410's built-in network connection provides remote viewing and control over PSTN, LAN/WAN, ISDN or DSL. The Windows-based remote software package allows secure operation and management of multiple HRHD units, including HRHD plus (4+, 9+, 16+) and HRHD1+. The DVR can be placed on a desktop or rack-mounted for easy access to the front panel controls. The convenient jog shuttle operates like a VCR while the intuitive, multi-lingual, GUI provides easy-to-use displays for everyday operation and system setup.

With its superior digital technology, flexible feature set, and user-friendly operation, the HRHD410 provides a powerful, digital solution for a variety of video surveillance applications.

FEATURES

- 4 Four looping video inputs
- Long-term video storage using XtraStor technology
- Displays high quality live video (720 x 480 NTSC; 720 x 576 PAL) with built-in hard drive options up to 750GB (up to three 250GB EIDE hard drives) and built-in CDRW
- Duplex recording mode with a capture rate up to 60 ips; simplex recording mode up to 120 ips
- Multiple search engines (Date/ Time, Calendar, Event)
- Various record modes (Time, Event, Pre-event and Panic)
- 4-channel audio recording/single-channel audio playback (records audio at 1ips or faster)
- Copy video clips directly to a USB storage device
- RS232/ RS485 ports to communicate with external devices such as modems, remote controls and dome cameras
- Scalable video recording:
336 x 224 or 672 x 224 – NTSC
336 x 272 or 672 x 272 – PAL
- Remote access through PSTN, LAN/ WAN (internal NIC), DSL and ISDN (remote access software included)
- Linux OS – embedded in flash

HRHD410

4-channel Digital Video Recorder

FEATURES AND BENEFITS:

High Resolution Image Capture

With up to 672 x 224 NTSC (672 x 272) PAL recording resolution, the HRHD410 digital recorder uses XtraStor technology to record and retrieve video from its internal disk storage. This advanced video compression technique permits long-term video storage. With a capture rate of up to 120ips in simplex mode and up to 60ips in duplex mode, critical information is processed accurately and efficiently.

Flexible Recording Options

The HRHD410 allows recording on up to four input cameras, allows selection of both the recording speed and picture quality, per camera. Further options exist to control recording by schedules, external inputs, or motion detection. This flexibility provides a customized video processing system for each installation.

Remote Access Software

Using the supplied Remote Access Software (RAS), you can control and configure your HRHD410 unit from virtually any location. The RAS program is an integrated software tool that controls system management, video monitoring and image playback of multiple HRHD410 and HRHD+ remote sites. The RAS software provides secure password protected communication.

Instantaneous Search and Retrieval

Recording digitally eliminates the need to search through hours of videotape. The HRHD410 allows for quick searches of its video database by event, calendar, or time/date.

Exceptional Picture Quality with XtraStor

The HRHD410 delivers crystal clear display resolution up to 720 x 480 NTSC (720 x 576 PAL). With its multiple, user-definable image quality settings per camera, the HRHD410 is flexible and meets the needs of the vast majority of applications. XtraStor technology enables high-quality video while using minimal hard drive space.

Advanced Video Encryption

Every recorded image contains a unique fingerprint that is chained with the preceding and succeeding images (chained-fingerprinting). This ensures that the video images cannot be modified with any available PC software enabling a solid chain of evidence.

Easy to Install, Configure and Operate

The HRHD410 works like a VCR. Its user-friendly GUI and front panel controls provide the benefits of digital recording, with minimal training. Its convenient jog shuttle dial allows video review using step-by-step or variable speed control.

Convenient Storage and Archive Options

HRHD410 offers large capacity storage of up to 750GB with S.M.A.R.T. monitoring. Images can be archived locally using the built-in CDRW, and its USB port can be used to copy video clips to an external USB hard disk drive, USB memory flash or USB CDRW. Video accessed via the Ethernet or modem connection using RAS software can also be saved as clip copy.

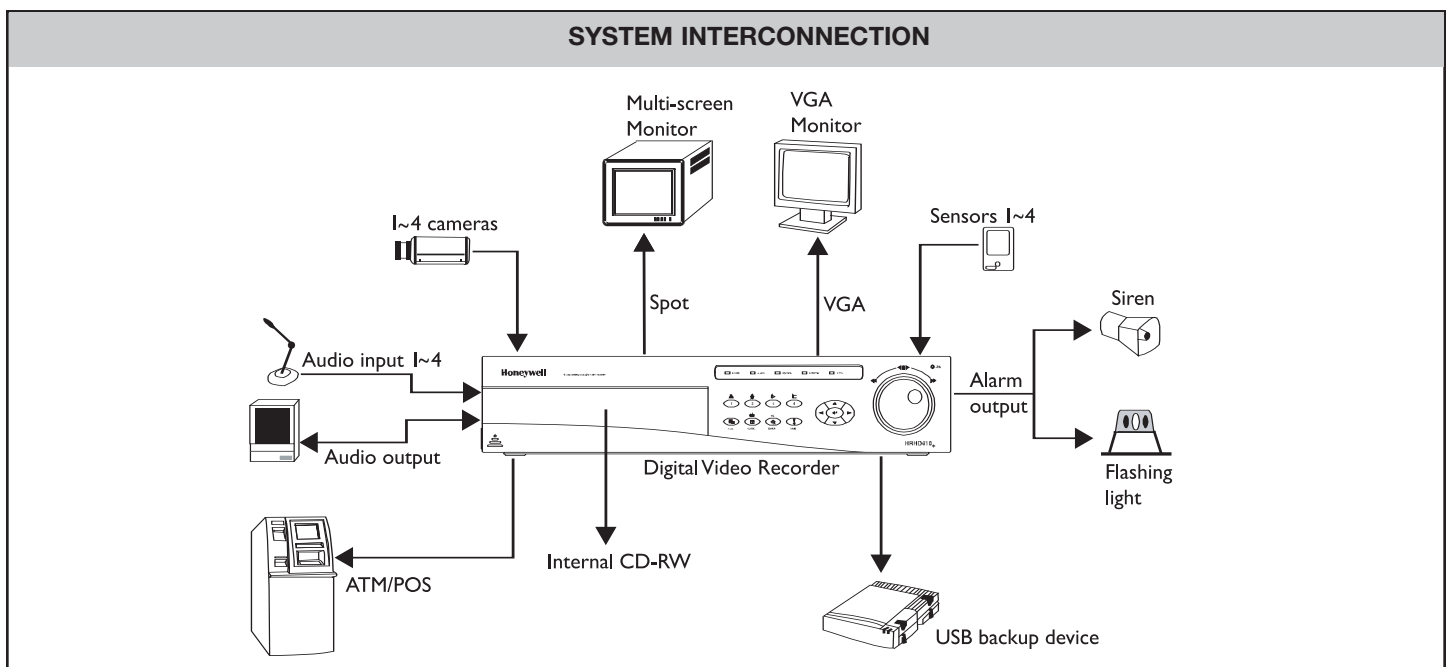

RECORDING TIMES

HRHD410 Recording Time (based on 160GB)									
Image Recording Compression Rate		Recording Picture Quality Mode (336 x 224 NTSC)							
		LOW 2 KB		STANDARD 4 KB		HIGH 8 KB		V-HIGH 12 KB	
(sec/imag)	(img/sec)	Hours	Days	Hours	Days	Hours	Days	Hours	Days
0.01	120	194	8.1	97	4.0	49	2.0	32	1.3
0.02	60	388	16.2	194	8.1	97	4.0	65	2.7
0.03	30	777	32.4	388	16.2	194	8.1	129	5.4
0.07	15	1,553	64.7	777	32.4	388	16.2	259	10.8
1.00	1	23,302	970.9	11,651	485.5	5,825	242.7	3,884	161.8

HRHD410 Recording Time (based on 320GB)									
Image Recording Compression Rate		Recording Picture Quality Mode (336 x 224 NTSC)							
		LOW 2 KB		STANDARD 4 KB		HIGH 8 KB		V-HIGH 12 KB	
(sec/imag)	(img/sec)	Hours	Days	Hours	Days	Hours	Days	Hours	Days
0.01	120	388	16.2	194	8.1	97	4.0	65	2.7
0.02	60	777	32.4	388	16.2	194	8.1	129	5.4
0.03	30	1,553	64.7	777	32.4	388	16.2	259	10.8
0.07	15	3,107	129.5	1,553	64.7	777	32.4	518	21.6
1.00	1	46,603	1,941.8	23,302	970.9	11,651	485.5	7,767	323.6

HRHD410 Recording Time (based on 750GB)									
Image Recording Compression Rate		Recording Picture Quality Mode (336 x 224 NTSC)							
		LOW 2 KB		STANDARD 4 KB		HIGH 8 KB		V-HIGH 12 KB	
(sec/imag)	(img/sec)	Hours	Days	Hours	Days	Hours	Days	Hours	Days
0.01	120	910	37.9	455	19.0	228	9.5	152	6.3
0.02	60	1,820	75.9	910	37.9	455	19.0	303	12.6
0.03	30	3,641	151.7	1,820	75.9	910	37.9	607	25.3
0.07	15	7,282	303.4	3,641	151.7	1,820	75.9	1,214	50.6
1.00	1	109,227	4,551.1	54,613	2,275.6	27,307	1,137.8	18,204	758.5

Record duration, or the quality of images that can be recorded on the HRHD's hard drive can vary from one half to two times the typical results shown in the charts above. These results are dependent on several factors, including the amount of activity or change in picture and the overall light level or noise in the video signal.

** When a user records audio, 6KB per channel shall be added to the above value.

HRHD410

4-channel Digital Video Recorder

SPECIFICATIONS

Video

- Signal Format: NTSC or PAL (Auto detect)
- Video Inputs:
 - Composite 4 looping inputs
 - 1 Vp-p, Auto-terminating, 75
- Monitor Outputs:
 - Composite: 1 output BNC
 - SVHS: 1 output Y/C
 - Analog RGB: 1 output VGA
- Display Resolution: 720 x 480 NTSC, 720 x 576 PAL
- Recoding Resolution:
336 x 224 or 672 x 224 NTSC; 336 x 272 or 672 x 272 PAL
- Playback/ Record Speed:
 - Simplex mode: 120 ips or 60 ips NTSC;
100 ips or 50 ips PAL
 - Duplex mode: 60 ips or 30 ips NTSC;
50 ips or 25 ips PAL

Audio

- Input: 4 lines in, RCA
- Output: 1 line output, RCA

Alarm

- Inputs: 4 TTL, programmable as NC/ NO
- Output: 2 Relay 0.5A @ 125VAC, 1A @ 30VDC, programmable as NC/NO
- Reset Input: 1 TTL

Approvals

- FCC, CE, UL

Network Connectivity

- RJ-45: 10/100 Mbps Base Ethernet
- RS-485: PTZ control or remote control option; Terminal block
- RS-232: Standard RS-232 connection for external modem, DB9 connector

Storage

- Storage: EIDE Hard Drives (up to 3) provide up to 750GB of internal storage with S.M.A.R.T. monitoring
- Clip Copy: Internal CDRW, USB HDD, USB CDRW, Memory Flash, via RAS

Ports

- USB: 1 port on front panel (USB1.11), Clip Copy

Operating System

- OS: Linux
- Firmware: OS in Flash Memory

Physical

- Dimensions (W x H x D):
16.9 in. x 3.5 in. x 14.0 in.(43.0 cm x 88 cm x 35.5 cm)
- Weight: 17.64 lbs (8.0 kg)
- Operating Temperature: 41°F to 104°F (5°C to 40°)
- Operating Humidity: 0% to 90%
- Power: 100 VAC to 240 VAC, 50/60 Hz
- Power Consumption: Max 70W

ORDERING

HRHD410 C 750 X

X PAL
NTSC

Storage

80GB Fixed IDE HDD **320GB** Fixed IDE HDD
160GB Fixed IDE HDD **500GB** Fixed IDE HDD
750GB Fixed IDE HDD

CD-RW - Internal CD-RW Drive (standard with all HRHD410 models)

Model

HRHD410 4-channel DVR

Honeywell Video Systems

171 Eileen Way
Syosset, NY 11791
800 796 CCTV

www.honeywell.com

Honeywell

L/HRHD410/D
February 2005
©2005 Honeywell International Inc.